

REV.	ECO/DDC	DESCRIPTION	DATE	DRAFT	CHECK	APV'D
A	----	RELEASED.	02-12-21	V.J.C.	T.D.N.	V.J.C.

DIMENSIONS IN INCHES [MM]		
HEIGHT-NOMINAL	HEIGHT-MINIMUM	HEIGHT-MAXIMUM
26.0 [660.4]	24.0 [609.6]	28.0 [711.2]
30.0 [762.0]	28.0 [711.2]	32.0 [812.8]
34.0 [863.6]	32.0 [812.8]	36.0 [914.4]
38.0 [965.2]	36.0 [914.4]	40.0 [1016.0]
42.0 [1066.8]	40.0 [1016.0]	44.0 [1117.6]

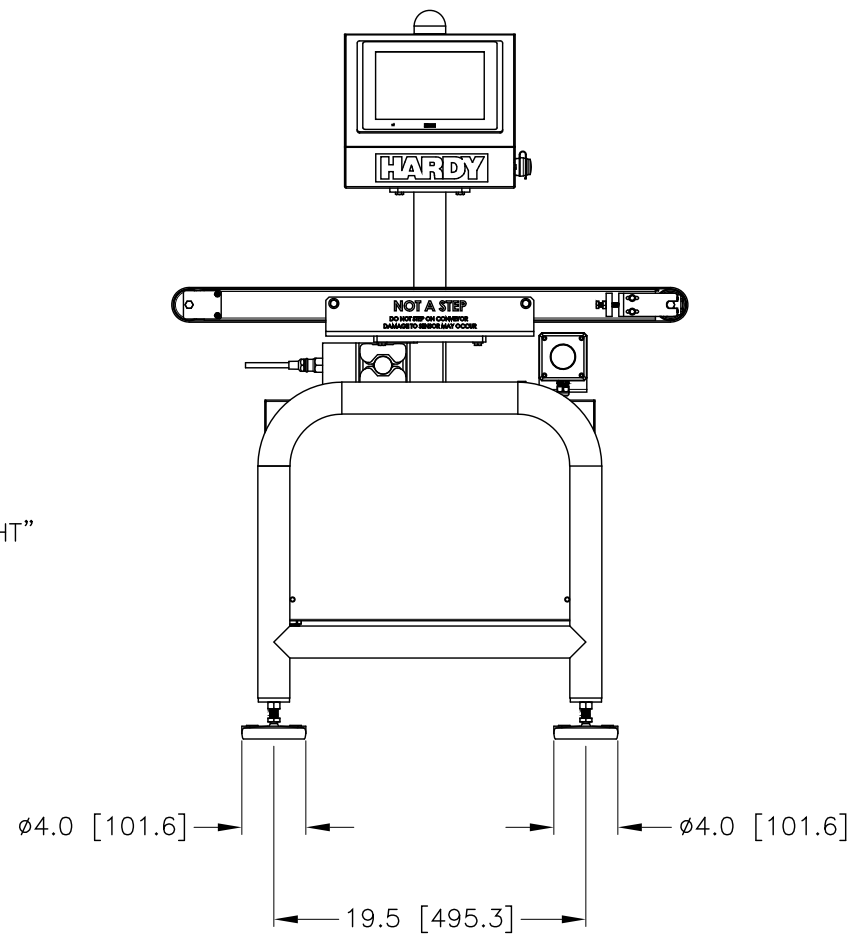
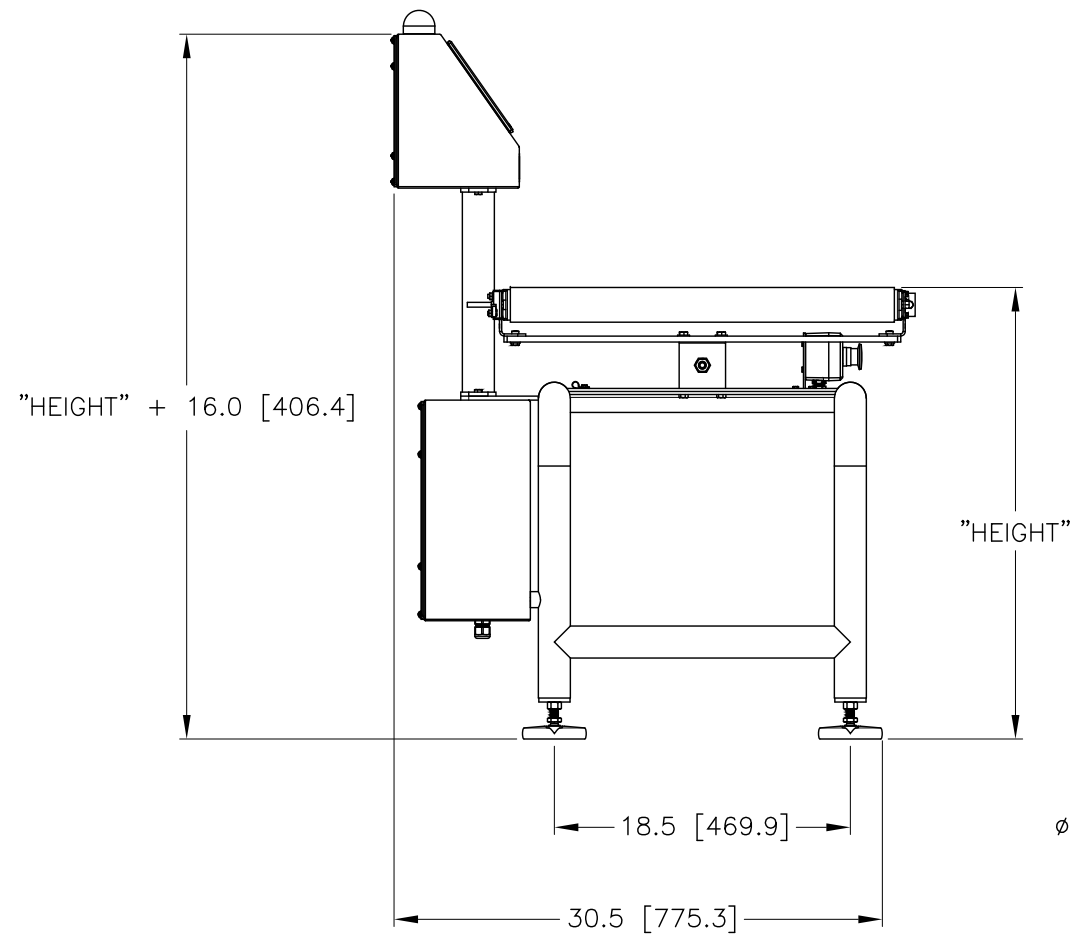
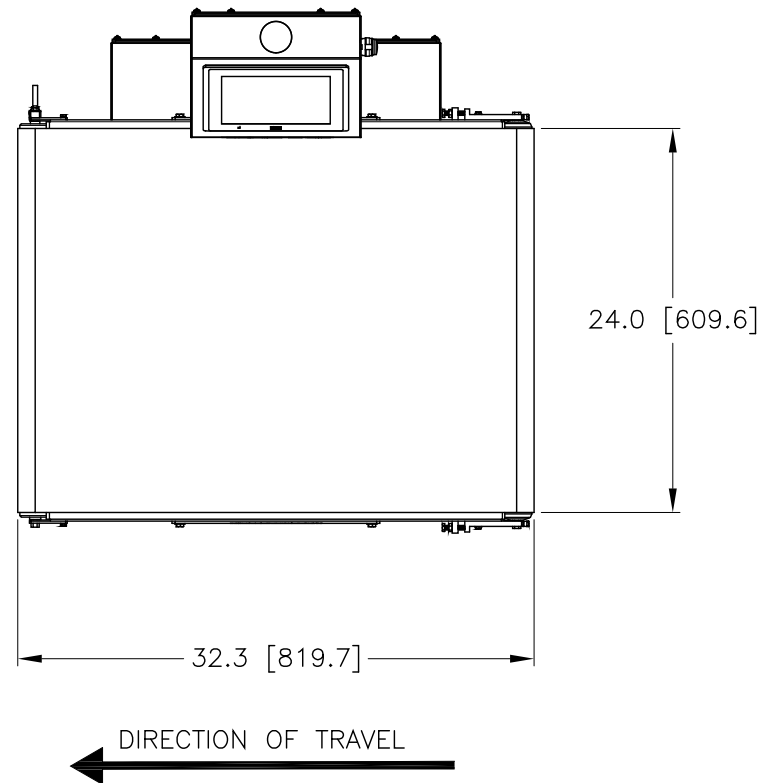

Customer Provided Variables				
Package Information				
Description:				
	Length (in)	Width (in)	Weight (lb.)	Rate (ppm)
Largest Pkg				
Smallest Pkg				
Material Handling				
	Infeed Speed (fpm)	Controlled Spacing (Y/N)	Minimum Package Pitch (in)	Package Direction (L-R, R-L)
Largest Pkg				
Smallest Pkg				
<i>Pitch to be stated as center to center spacing of one package to the next</i>				
Belt Type (check one):	<input type="checkbox"/> Black(PVC)	<input type="checkbox"/> White(FDA)		
Roller (check one):	<input type="checkbox"/> Galv (IP54)	<input type="checkbox"/> SS (IP66)		
Construction (check one):	<input type="checkbox"/> Painted	<input type="checkbox"/> Stainless		
Performance				
Maximum Rcmd. Weight	Maximum Speed	Enviro. Rating	Voltage / Current	Air (Reject Only)
40 lbs	120FPM		120 VAC / 5 AMP	80 PSI / 4 CFM
Customer Approval Signature _____				
Print Name _____				
Date _____				

NOTES: UNLESS OTHERWISE SPECIFIED

PROPRIETARY NOTICE
 ALL DATA AND INFORMATION CONTAINED IN OR DISCLOSED BY THIS DOCUMENT IS CONFIDENTIAL AND PROPRIETARY INFORMATION OF HARDY PROCESS SOLUTIONS INC. AND ALL RIGHTS THEREIN ARE EXPRESSLY RESERVED. BY ACCEPTING THIS MATERIAL THE RECIPIENT AGREES THAT THIS MATERIAL AND THE INFORMATION CONTAINED THEREIN IS HELD IN CONFIDENCE AND IN TRUST AND SHALL NOT BE USED, COPIED, REPRODUCED IN WHOLE OR IN PART, NOR ITS CONTENTS REVEALED IN ANY MANNER TO OTHERS, EXCEPT TO MEET THE SPECIFIC PURPOSE FOR WHICH IT WAS DELIVERED.

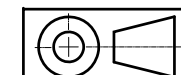

		0588-0194	LAYOUT DRAWING, HPS-CW2, 24"x32", RIGHT TO LEFT DIRECTION		
ITEM	QTY	PART NUMBER	DESCRIPTION	COMMENTS	
PARTS LIST					
UNLESS OTHERWISE SPECIFIED DIMENSIONS ARE IN INCHES TOLERANCES ARE:		CONTRACT NO.		 LAYOUT DRAWING, HPS-CW2, 24"x32", RIGHT TO LEFT DIR	
FRACTIONS: N/A		APPROVALS			
DECIMALS: .XX = ±.03 .XXX = ±.010		DRAWN V. CHULA	DATE 01-26-21		
ANGLES: ±0°, 30°		CHECKED T. NORMAN	DATE 02-12-21		
MATERIAL		APPROVED V. CHULA	DATE 02-12-21	SIZE	FSCM
FINISH		ISSUED V. CHULA	DATE 02-12-21	D	21316
DO NOT SCALE DRAWING		PRODUCTION	DATE	DRAWING NO.	REV.
				0588-0194	A
		FILE NAME: 0588-0194A1.DWG		SCALE: NONE	SHEET 1 OF 1