

REV.	ECO/DDC	DESCRIPTION	DATE	DRAFT	CHECK	APV'D
A	----	RELEASED.	03-16-17	V.J.C.	E.M.J.	V.J.C.

JUNCTION BOX FIELD WIRING TERMINAL BLOCKS

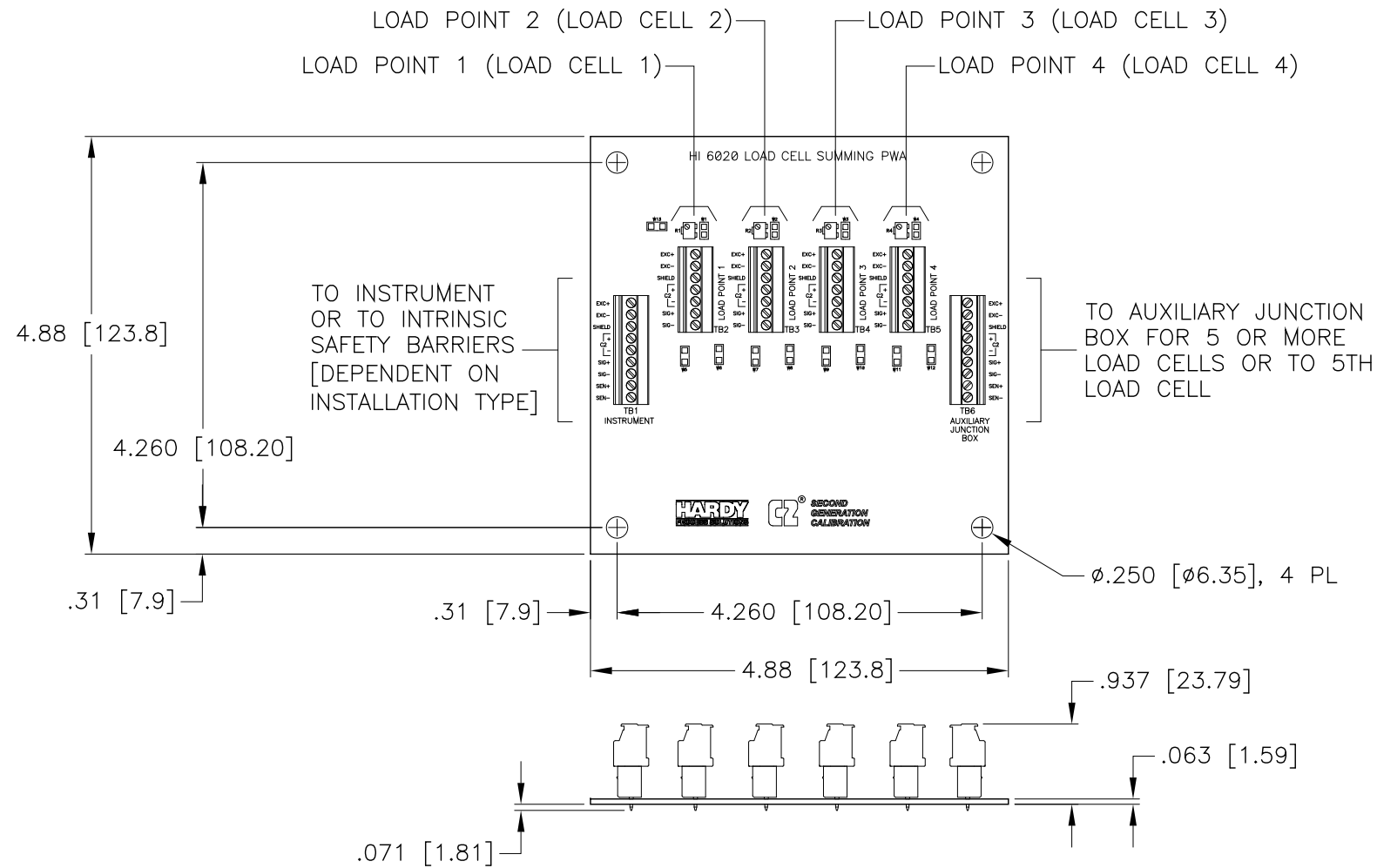

HI 6020JB SERIES LOAD CELL SUMMING CARD
DIMENSIONS IN INCHES [MM]

- 7 OPTIONAL TRIM POTS CANNOT BE USED WITH C2 LOAD SENSORS.
6. SEE SHEET 2 FOR ENCLOSURE MOUNTING DIMENSIONS.
5. REFER TO GENERAL CONTROL DRAWING 0594-0011 FOR HAZARDOUS AREA USAGE GUIDELINES AND SYSTEM INTERCONNECT INFORMATION.
- 4 WHEN A CABLE GLAND CORD GRIP IS NOT USED, A CABLE GLAND HOLE PLUG MUST BE INSERTED INTO THE HOLE TO PREVENT WATER AND/OR DUST INGRESS INTO THE ENCLOSURE.
- 3 CABLE GLANDS ARE NOT SUPPLIED WITH THE JUNCTION BOX. CABLE GLANDS MUST BE USED THAT ARE APPROPRIATELY RATED FOR THE SUMMING BOX HAZARDOUS AREA LOCATION.
2. USE HARDY PROCESS SOLUTIONS CERTIFIED LOAD CELL CABLE MODEL NO. C2 CABLE [PN 6020-0001-0].
1. REFER TO LOAD CELL CAL SHEET OR WEIGHING ASSEMBLY SELECTION GUIDE FOR LOAD CELL WIRING COLOR CODE.

NOTES: UNLESS OTHERWISE SPECIFIED

PROPRIETARY NOTICE
ALL DATA AND INFORMATION CONTAINED IN OR DISCLOSED BY THIS DOCUMENT IS CONFIDENTIAL AND PROPRIETARY INFORMATION OF HARDY PROCESS SOLUTIONS INC. AND ALL RIGHTS THEREIN ARE EXPRESSLY RESERVED. BY ACCEPTING THIS MATERIAL THE RECIPIENT AGREES THAT THIS MATERIAL AND THE INFORMATION CONTAINED THEREIN IS HELD IN CONFIDENCE AND IN TRUST AND SHALL NOT BE USED, COPIED, REPRODUCED IN WHOLE OR IN PART, NOR ITS CONTENTS REVEALED IN ANY MANNER TO OTHERS, EXCEPT TO MEET THE SPECIFIC PURPOSE FOR WHICH IT WAS DELIVERED.

MODEL NUMBERS 7

HI 6020JB-SS1-6-EX	DESCRIPTION
EX	= RATED FOR ATEX/IECEX ZONE 0 GROUP IIC AREAS
BLANK	= WITHOUT EXPANSION PORT
6	= WITH EXPANSION PORT
1	= WITHOUT TRIM POTS
2	= WITH TRIM POTS
SS	= STAINLESS STEEL ENCLOSURE

CONTROLLED DRAWING
CHANGES MAY NOT BE MADE
WITHOUT APPROVAL FROM
CERTIFICATION AGENCY

ITEM	QTY	0584-0102	I/I DIAGRAM, HI 6020JB-SS-EX SERIES		COMMENTS
		PART NUMBER	DESCRIPTION		
PARTS LIST					
UNLESS OTHERWISE SPECIFIED DIMENSIONS IN INCHES [MM] TOLERANCES: FRACTIONS: N/A DECIMALS: .XX = ±.03 [.8] .XXX = ±.010 [.25] ANGLES: ±0°, 30°		CONTRACT NO.		HARDY PROCESS SOLUTIONS I/I DIAGRAM, HI 6020JB-SS-EX SERIES	
MATERIAL		APPROVALS			
FINISH		DRAWN V. CHULA	DATE 02-24-17		
DO NOT SCALE DRAWING		CHECKED E. JAMES	DATE 03-16-17		
		APPROVED V. CHULA	DATE 03-16-17	SIZE D	FSCM 21316
		ISSUED V. CHULA	DATE 03-16-17	DRAWING NO. 0584-0102	REV. A
		PRODUCTION	DATE	FILE NAME: 584102A1.DWG	SCALE: NONE
				SHEET 1 OF 2	

HI 6020JB-SS1-EX SERIES
 HI 6020JB-SS2-EX SERIES
 (STAINLESS STEEL ENCLOSURE)

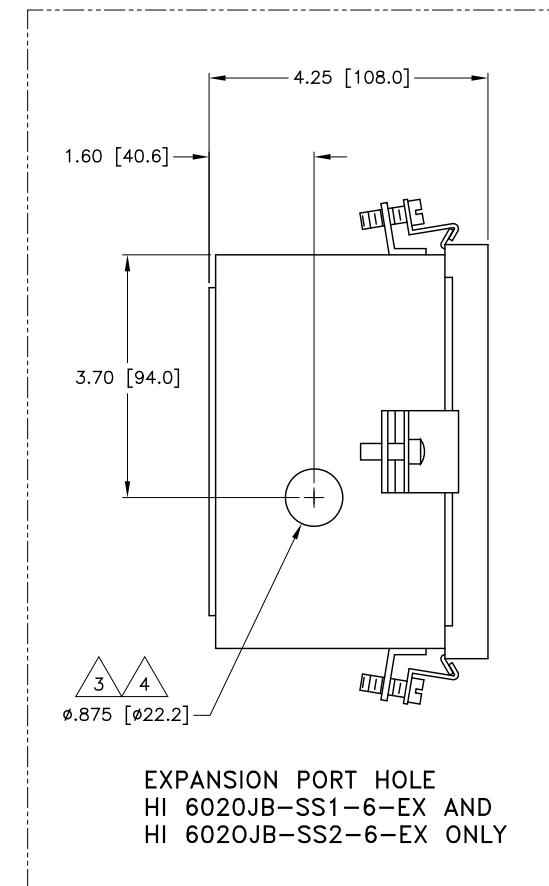
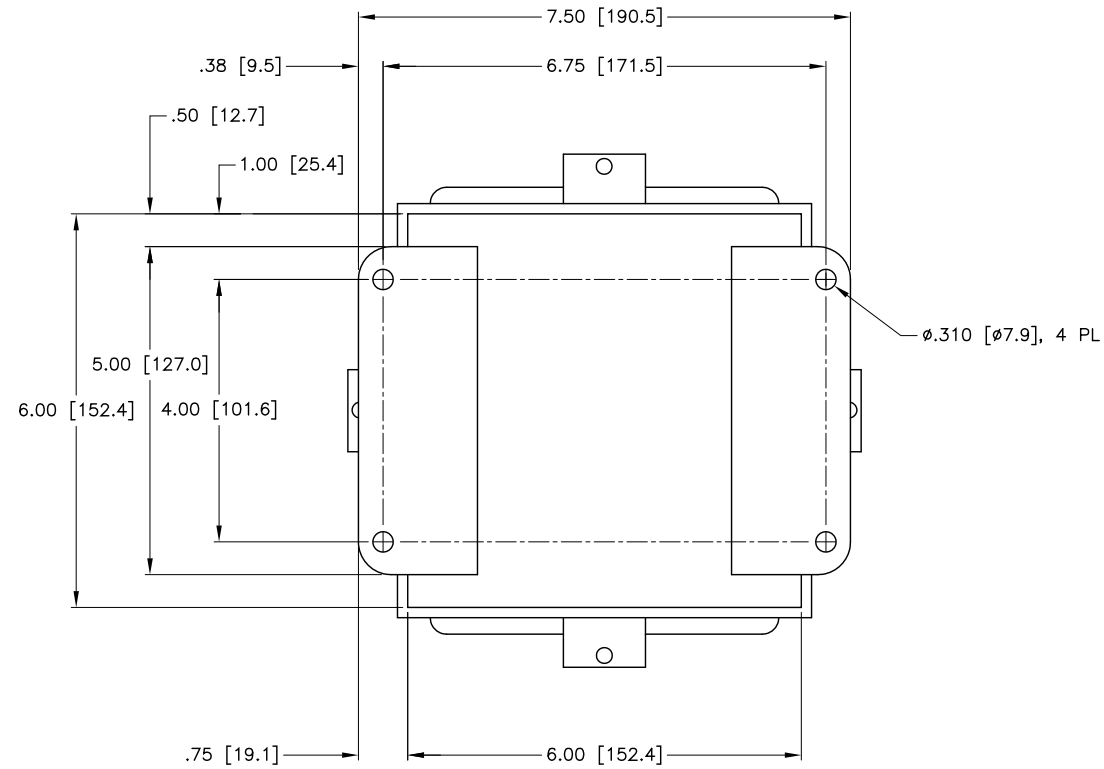
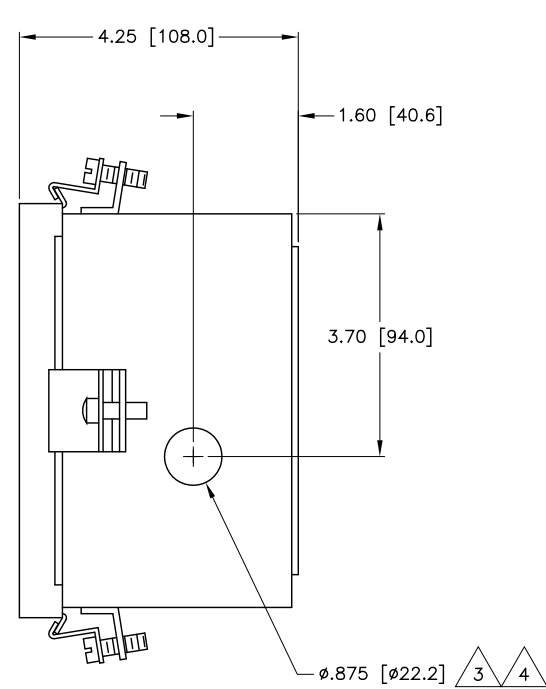
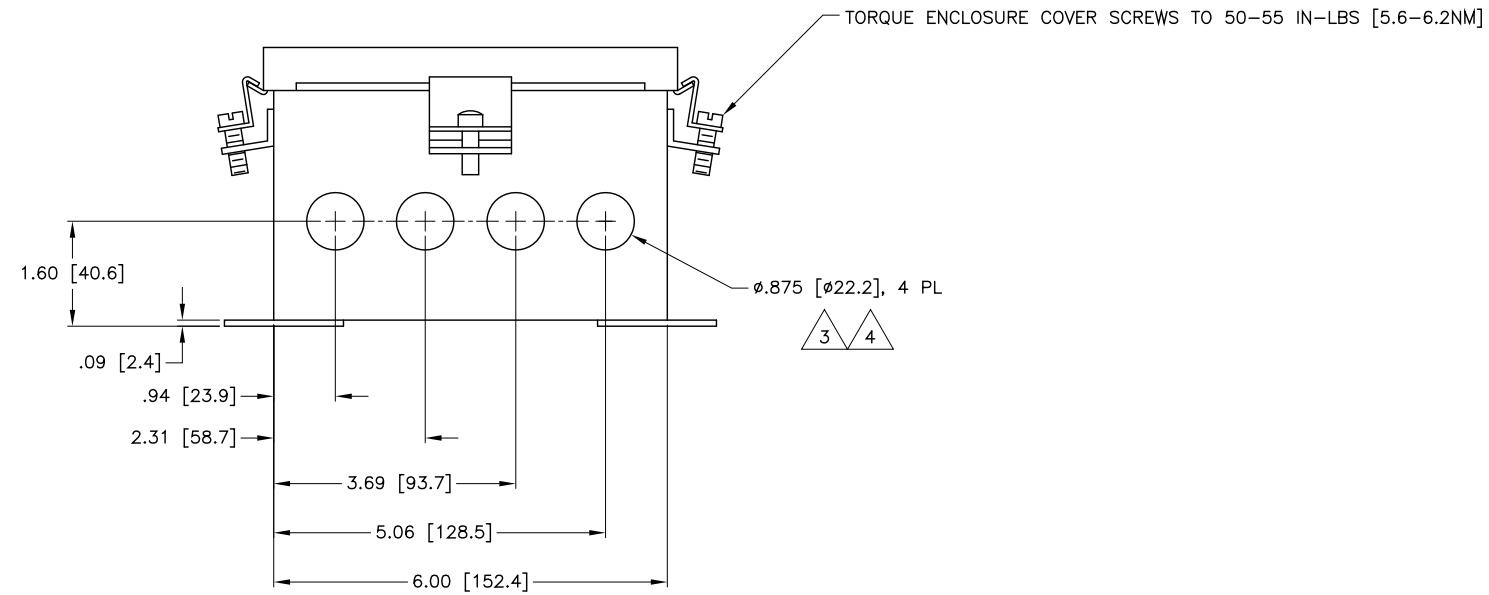

DIMENSIONS IN INCHES [MM]



TITLE			
I/I DIAGRAM, HI 6020JB-SS-EX SERIES			
SIZE	FSCM	DRAWING NO.	REV.
D	21316	0584-0102	A
FILE NAME: 584102A1.DWG		SCALE: NONE	SHEET 2 OF 2