

Rev	ECN/DDC	DESCRIPTION	DATE	DRAFT	CHECK	APV'D
A		Initial Release	10-14-16	E.M.J.	--	--
B		Revised To Correct Text Errors	11-08-16	V.J.C.	--	--
C		Removed ATEX/IECEX Notations.	02-23-17	V.J.C.	E.M.J.	V.J.C.
D		Incorporated Agency Requested Changes.	04-06-17	V.J.C.	E.M.J.	V.J.C.
E		Incorporated Agency Requested Changes.	04-07-17	V.J.C.	E.M.J.	V.J.C.
F		Incorporated Agency Requested Changes.	04-12-17	V.J.C.	E.M.J.	V.J.C.
G	12044	Revised Per ECN.	12-10-19	V.J.C.	J.I.	V.J.C.

**The notes below apply to all 6 pages in this control document**

1. No revision to the drawing without prior UL approval.
2. Associated apparatus manufacturer's installation drawing must be followed when installing this equipment.
3. Install Intrinsic Safe Barriers in accordance with barrier instructions.
4. The total combined length of all wiring in the system, including the cable from each associated apparatus to and from the summing box, and to each load cell must not exceed 300 feet.
5. Installation should be in accordance with any applicable local electrical code, which may include ANSI/ISA RP12.06.01 "Installation of Intrinsically Safe System for Hazardous (Classified) Locations," the electrical safety code (ANSI/NFA 70) Article 504.
6. The product option for use in both Class I,II,III Division 1 and 2 areas (NEC 501, 502) and Class 1, Zone 0 and 2, Group IIC, and Zone 20 and 22, Group IIIC areas (NEC 505, 506) is the HI 6020IT-SSX-Y (shipped with cable glands):  
SS = Stainless Steel enclosure  
X = 1 is without trim pots, and X=2 is with trim pots  
Y = blank is a 5-hole summing box enclosure, and Y=6 is a 6-hole summing box enclosure enabling connection to a second summing box
7. SB (summing box) maximum cable length 250 ft; used between the summing box and IS barriers.

**WARNINGS:**

1. To prevent ignition of flammable or combustible atmospheres, disconnect power before servicing

*Substitution of components may impair Intrinsic Safety and/or void Hazardous Area Approval*

<b>HARDY PROCESS SOLUTIONS</b>					
TITLE <b>General Control Drawing, Hazardous Area Apparatus System with HI 6020IT-SSX-Y, Load sensor and Load Points, US &amp; Canada</b>					
SIZE <b>D</b>	FSCM <b>21316</b>	DRAWING NO. <b>0594-0008</b>	REV. <b>G</b>		
FILE NAME:	<b>0594-0008G1.VSD</b>	SCALE:	<b>NONE</b>	SHEET	<b>1</b> OF <b>6</b>

Intrinsic Safety Barriers Approved For Use In This System (US/Canada)										
Component Description	Supplier	Model	Class	Division	Group	U <sub>o</sub> (V)	I <sub>o</sub> (mA)	P <sub>o</sub> (mW)	C <sub>o</sub> (uF)	L <sub>o</sub> (mH)
IS Barrier Type 1 (excitation)	MTL	7766Pac	I,II,III	1	AB	12.0	157.0	471.0	1.41	1.47
					CE				9.00	4.40
					DFG				36.00	11.00
IS Barrier Type 2 (signals & sense)		7761Pac	I,II,III	1	AB	9.0	26.0	225.0	4.90	56.00
					CE				40.00	208.00
					DFG				500.00	419.00
IS Barrier Type 3 (C2)		7710+	I,II,III	1	AB	10.0	200.0	500.0	3.00	0.91
					CE				20.00	2.72
					DFG				100.00	7.25
IS Barrier Type 1 (excitation)	Pepperl+Fuchs	Z966.H	I,II,III	1	ABCD	12.0	164.0	492.0	1.41	1.38
					EFG				4.23	4.14
					DFG				11.28	11.04
IS Barrier Type 2 (signals & sense)		Z961.H	I,II,III	1	AB	8.7	25.0	54.4	4.9	57.0
					CE				14.7	171.0
					DFG				39.2	456.0
IS Barrier Type 3 (C2)		Z710	I,II,III	1	AB	9.56	195.0	466.1	3.0	0.86
					CE				9.0	2.58
					DFG				24.0	6.88
IS Barrier Type 1 (excitation)	Stahl	9002/11-130-360-001	I,II,III	1	ABE	13.0	321.0	1040.0	1.0	0.19
					CDFG				6.2	1.6
IS Barrier Type 2 (signals & sense)		9002/10-187-020-001	I,II,III	1	ABE	9.33	20.0	50.0	3.9	90.0
					CDFG				29.0	330.0
IS Barrier Type 3 (C2)		9001/01-086-150-101	I,II,III	1	ABE	8.6	150.0	322.5	6.2	1.3
					CDFG				55.0	7.0

Notes:

- For more information, please refer to the Zener barrier manufacturer control drawings.
- IS Barriers used within a single system must be from the same supplier. Do not mix barrier suppliers within the same system.

*Substitution of components may impair Intrinsic Safety and/or void Hazardous Area Approval*

<b>HARDY PROCESS SOLUTIONS</b>			
TITLE <b>General Control Drawing, Hazardous Area Apparatus System with HI 6020IT-SSX-Y, Load sensor and Load Points, US &amp; Canada</b>			
SIZE <b>D</b>	FSCM <b>21316</b>	DRAWING NO. <b>0594-0008</b>	REV. <b>G</b>
FILE NAME: <b>0594-0008G1.VSD</b>		SCALE: <b>NONE</b>	SHEET <b>2</b> OF <b>6</b>

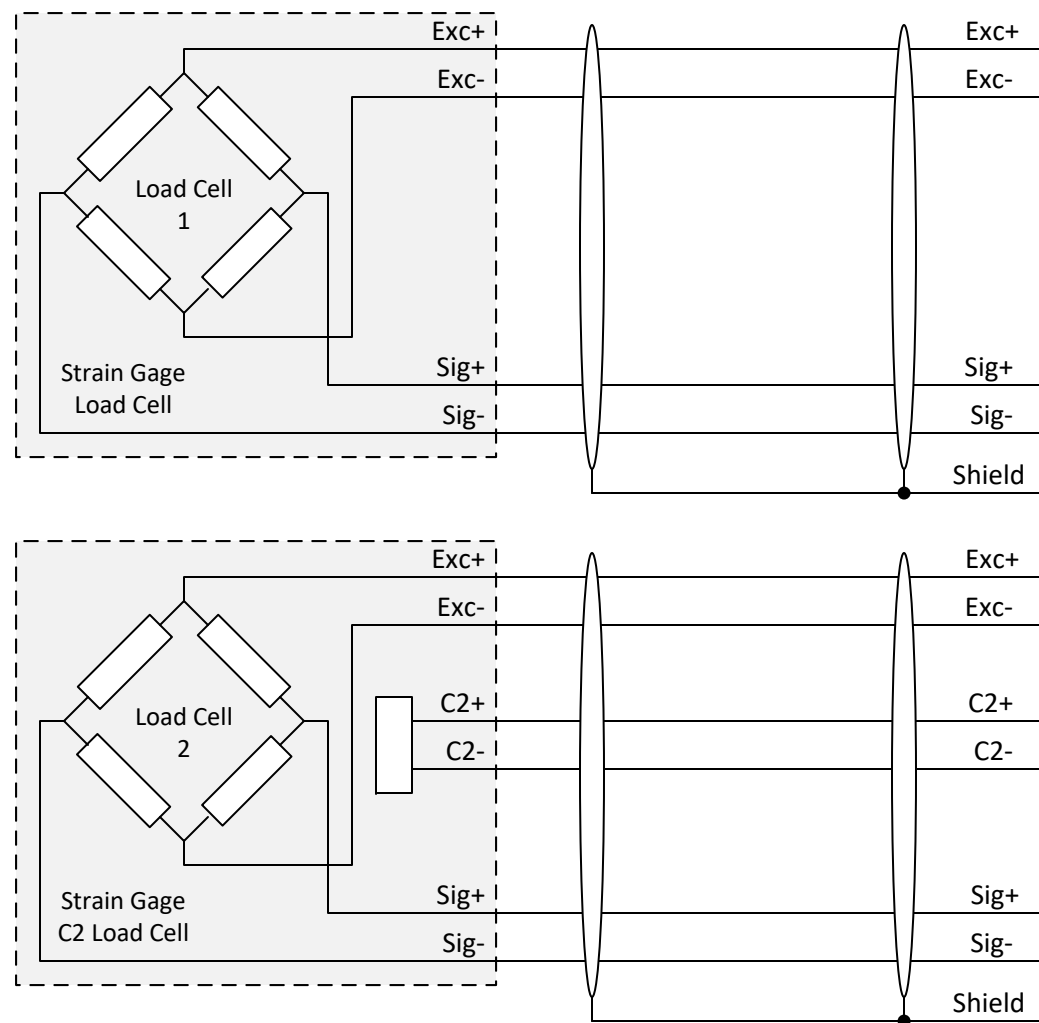

**Terminology:**

**Load Sensor** = Load Cell or C2 Load Cell  
**Load Point** = Load Sensor and Mounting Hardware

**Load Cell or C2 Load Cell Wiring to Connectors TB2, TB3, TB4 & TB5 on HI 6020IT Series Summing Card**

Load Cell I.S. Entity Parameters			
Component Description	U <sub>o</sub> (V)	I <sub>o</sub> (mA)	P <sub>o</sub> (mW)
Load Sensor or Load Point	29.9	511	1470
C2 Load Sensor or Load Point	29.9	511	1470

**This device is intended for connection to load cells which are considered simple apparatus with the following parameters:**

**C<sub>i</sub> = 0uF**

**L<sub>i</sub> = 0uF**

**The entity concept allows interconnection of intrinsically safe apparatus with associated apparatus when the following is true:**

[Field device]	[Barrier]
V <sub>max</sub> or U <sub>i</sub>	≥ V <sub>oc</sub> , V <sub>t</sub> , or U <sub>o</sub>
I <sub>max</sub> or I <sub>i</sub>	≥ I <sub>sc</sub> , I <sub>t</sub> , or I <sub>o</sub>
P <sub>max</sub> or P <sub>i</sub>	≥ P <sub>o</sub>
C <sub>i</sub> + C <sub>cable</sub>	≤ C <sub>a</sub> or C <sub>o</sub>
L <sub>i</sub> + L <sub>cable</sub>	≤ L <sub>a</sub> or L <sub>o</sub>

*Substitution of components may impair Intrinsic Safety and/or void Hazardous Area Approval*

<b>HARDY PROCESS SOLUTIONS</b>				
TITLE <b>General Control Drawing, Hazardous Area Apparatus System with HI 6020IT-SSX-Y, Load sensor and Load Points, US &amp; Canada</b>				
SIZE <b>D</b>	FSCM <b>21316</b>	DRAWING NO. <b>0594-0008</b>	REV. <b>G</b>	
FILE NAME: <b>0594-0008G1.VSD</b>		SCALE: <b>NONE</b>	SHEET <b>3</b>	OF <b>6</b>

**Class I, Division 1, Groups A, B, C, D, T4**  
**Class II, Division 1, Groups E, F, G, T4**  
**Class III, Division 1, T4**  
**Class I, Zone 0, Group IIC, T4**  
**Class II, Zone 20, Group IIIC, T4**  
**Hazardous Areas**

**Class I, Division 2, Groups A, B, C, D,**  
**Or Unclassified Area**

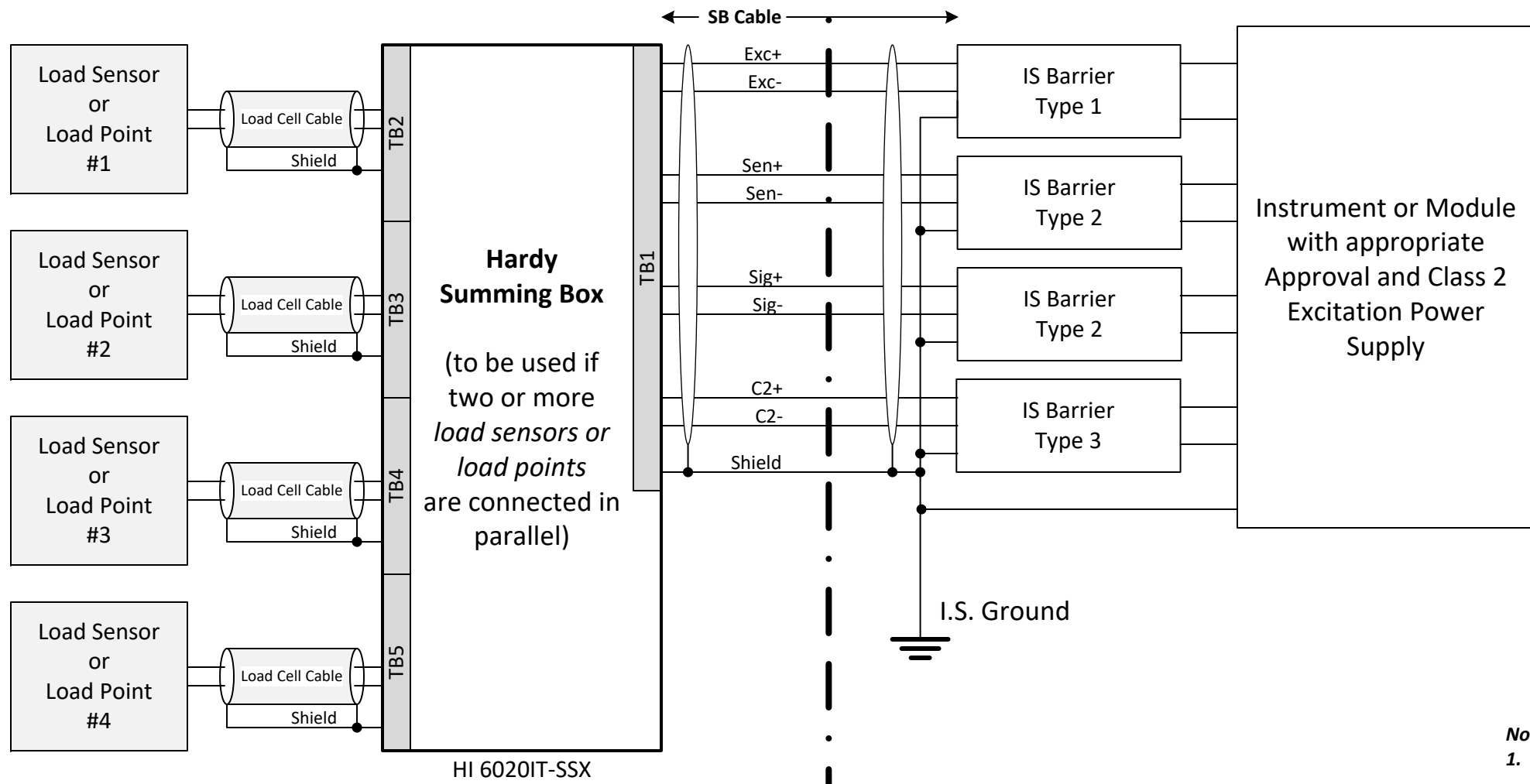

**Notes:**

1. *Optional IS barrier on the sense lines is used to automatically compensate for losses through the IS barrier on the excitation lines. If the sense lines are not used, the IS Barrier for the sense lines is not required*
2. *For customers using an instrument or module without a Class 2 rated excitation power supply, a separate Class 2 power supply can be used to power IS Barrier Type 1.*

*Substitution of components may impair Intrinsic Safety and/or void Hazardous Area Approval*

# HARDY PROCESS SOLUTIONS

TITLE  
**General Control Drawing, Hazardous Area Apparatus System with HI 6020IT-SSX-Y, Load sensor and Load Points, US & Canada**

SIZE <b>D</b>	FSCM <b>21316</b>	DRAWING NO. <b>0594-0008</b>	REV. <b>G</b>
------------------	----------------------	---------------------------------	------------------

**Class I, Division 1, Groups A, B, C, D, T4**  
**Class II, Division 1, Groups E, F, G, T4**  
**Class III, Division 1, T4**  
**Class I, Zone 0, Group IIC, T4**  
**Class II, Zone 20, Group IIIC, T4**  
**Hazardous Areas**

**Class I, Division 2, Groups A, B, C, D**  
**Or Unclassified Area**

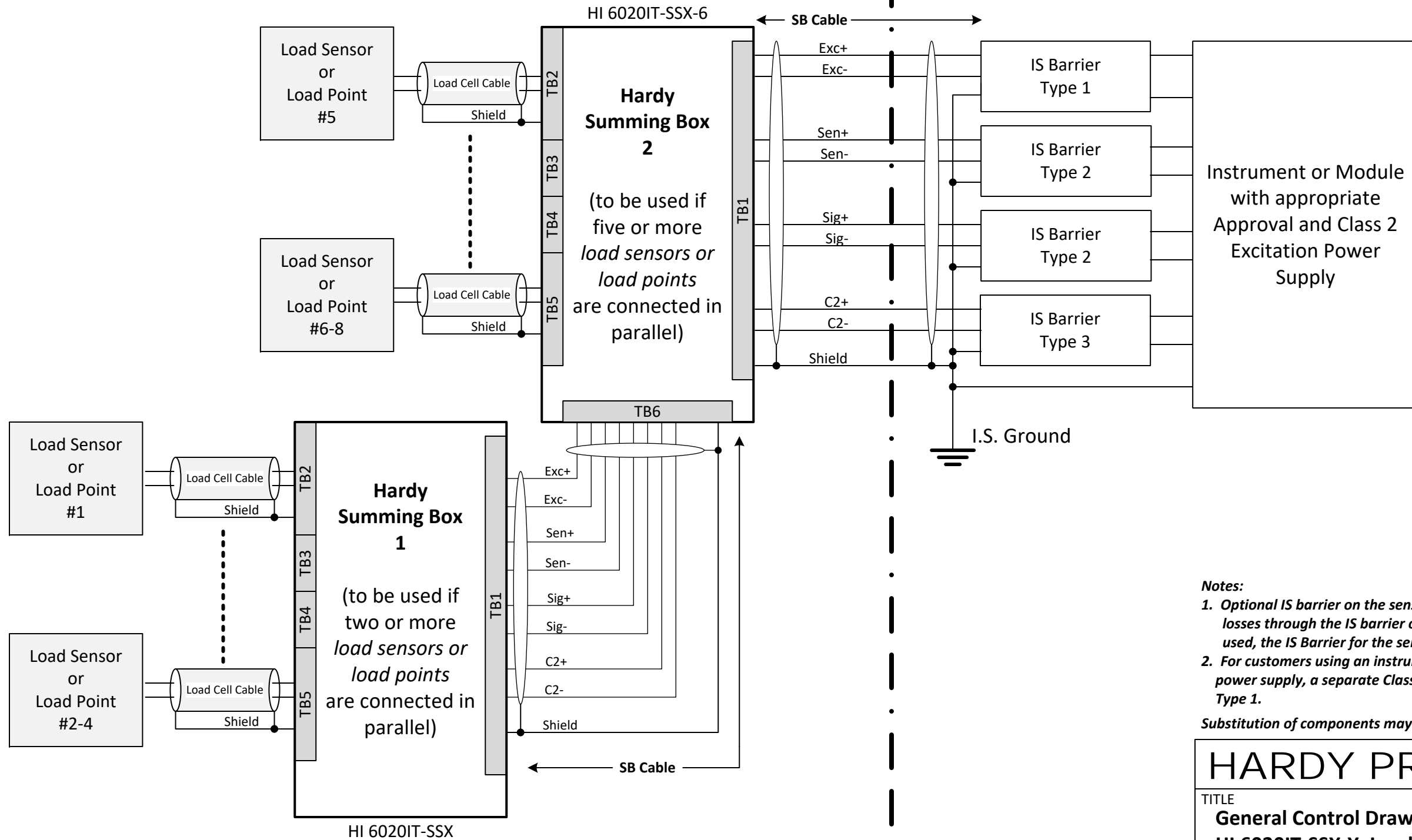

**Notes:**

- Optional IS barrier on the sense lines is used to automatically compensate for losses through the IS barrier on the excitation lines. If the sense lines are not used, the IS Barrier for the sense lines is not required
- For customers using an instrument or module without a Class 2 rated excitation power supply, a separate Class 2 power supply can be used to power IS Barrier Type 1.

*Substitution of components may impair Intrinsic Safety and/or void Hazardous Area Approval*

# HARDY PROCESS SOLUTIONS

TITLE  
**General Control Drawing, Hazardous Area Apparatus System with HI 6020IT-SSX-Y, Load sensor and Load Points, US & Canada**

SIZE <b>D</b>	FSCM <b>21316</b>	DRAWING NO. <b>0594-0008</b>	REV. <b>G</b>
FILE NAME: <b>0594-0008G1.VSD</b>		SCALE: <b>NONE</b>	SHEET <b>5</b> OF <b>6</b>

LOAD POINT 2 (LOAD CELL 2)  
LOAD POINT 1 (LOAD CELL 1)

LOAD POINT 3 (LOAD CELL 3)  
LOAD POINT 4 (LOAD CELL 4)

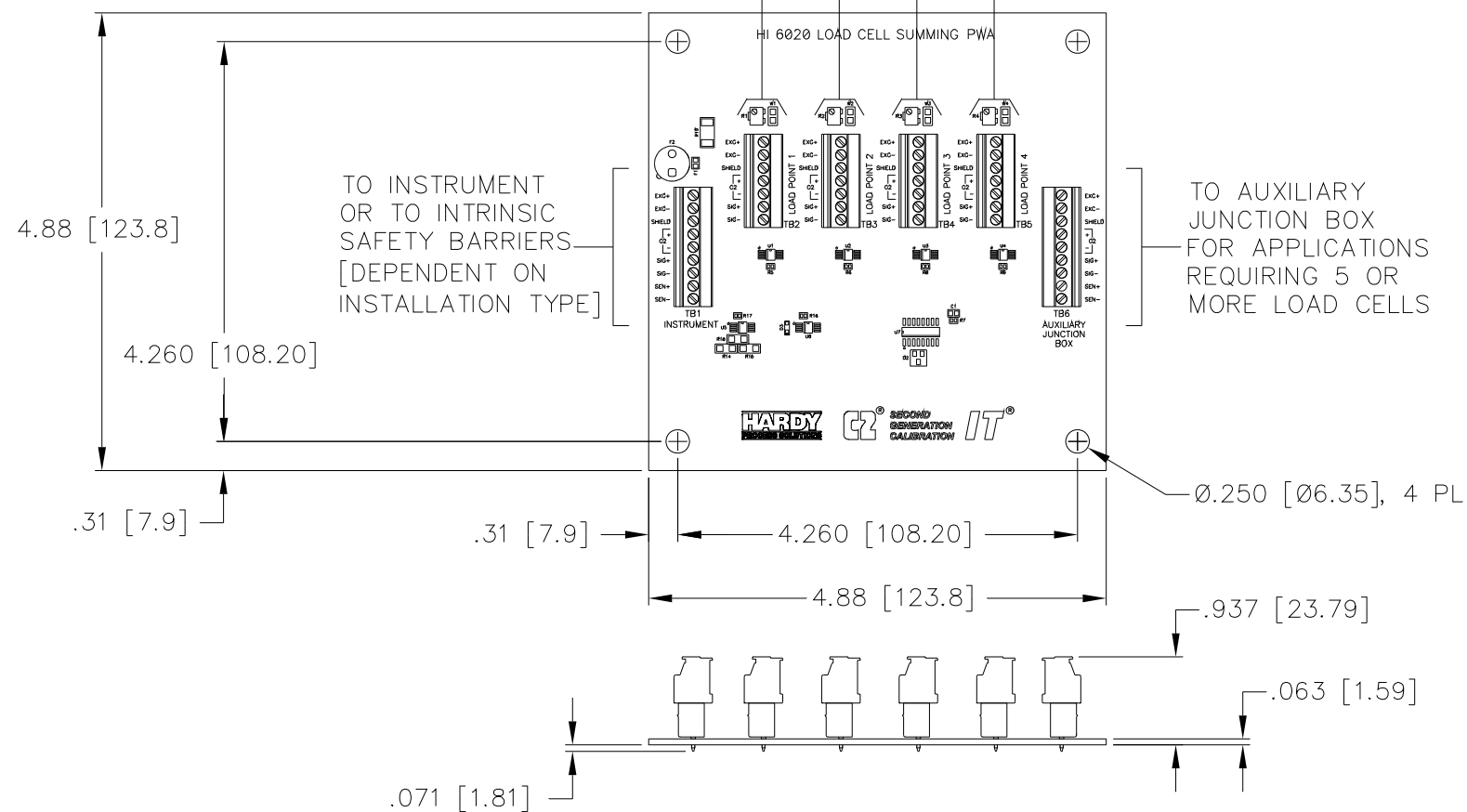

**Notes for summing box and the HI 6020IT summing card**

1. Refer to load cell Calibration sheet or weighing assembly selection guide for load cell wiring code.
2. Optional trim pots can not be used with C2 load sensors or C2 load points.
3. Load Cell wire tightening torque for the terminal blocks is 2lb-in minimum to 4lb-in maximum.
4. The following parts are shipped inside the summing box and are to be installed in locations required by the customer.

ITEM	PART NUMBER	QTY	DESCRIPTION
(1)	6007-0097-0	6	½ NPT Cord Grip and Sealing Nut
(2)	2814-0095-0	6	½ NPT Lock Nut
(3)	2545-0009	6	½ NPT Liquid Tight Plug

**Installation Instructions**  
Torque setting = 50-55 in/lb, 5.6 – 6.2 Nm  
Torque setting = 40-45 in/lb, 4.5 – 5.1 Nm  
To be installed when cable gland is not used

The above parts are suitable for:

Class I, Division 1, Groups A, B, C, D, T4  
Class II, Division 1, Groups E, F, G, T4  
Class III, Division 1, T4  
Class I, Zone 0, Group IIC, T4  
Class II, Zone 20, Group IIIC, T4

Class I, Division 2, Groups A, B, C, D, T5  
Class II, Division 2, Groups F, G, T5  
Class III, Division 2, T5

5. When a cable gland cord grip is not used a cable gland hole plug must be inserted into the hole to prevent water and/or dust ingress into the enclosure.
6. The screws on the summing box front cover must be tightened to a torque setting of 50-55 in/lb, 5.6 – 6.2 Nm.

**CABLE CONNECTION**

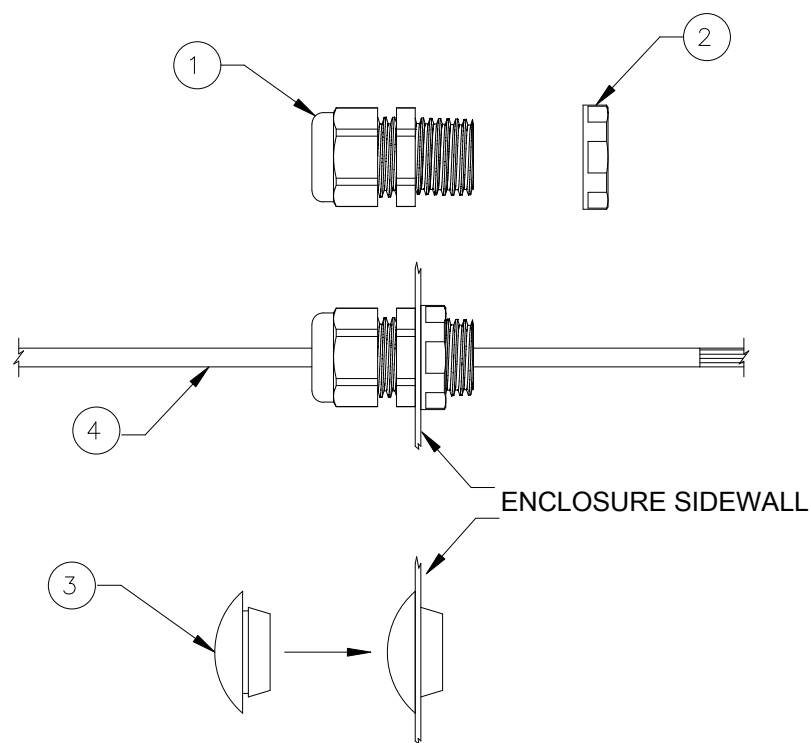

- 1 Cable Gland Cord Grip and Sealing Nut
- 2 Cable Gland Lock Nut
- 3 Cable Gland Hole Plug
- 4 Load Cell Cable

Substitution of components may impair Intrinsic Safety and/or void Hazardous Area Approval

<b>HARDY PROCESS SOLUTIONS</b>				
TITLE <b>General Control Drawing, Hazardous Area Apparatus System with HI 6020IT-SSX-Y, Load sensor and Load Points, US &amp; Canada</b>				
SIZE <b>D</b>	FSCM <b>21316</b>	DRAWING NO. <b>0594-0008</b>	REV. <b>G</b>	
FILE NAME:	<b>0594-0008G1.VSD</b>	SCALE:	<b>NONE</b>	SHEET <b>6</b> OF <b>6</b>