

# Footed Advantage® Load Cells

## HI SBHF14, HI SBHC14 and HI HBB01 Footed Hermetic Shear Beam Sensors

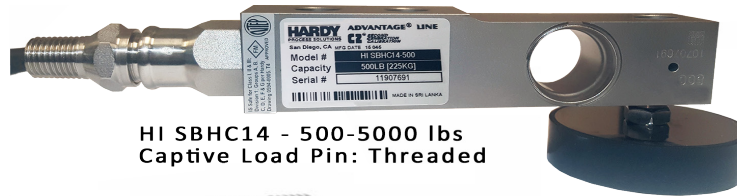

HI SBHC14 - 500-5000 lbs  
Captive Load Pin: Threaded



### Applications

- Platform Scales
- Tank Weighing
- Hoppers
- Conveyor Systems



HI HBB01 - 22-1100 lbs  
Captive Load Pin: Threaded

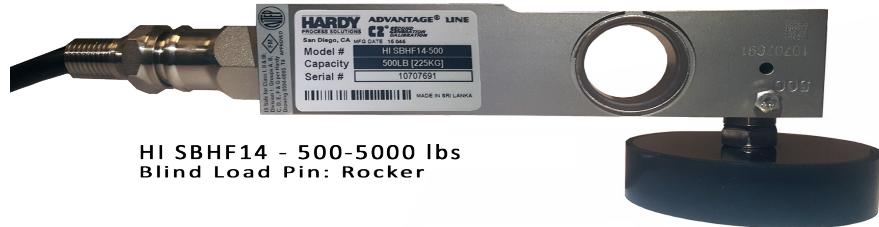

HI SBHF14 - 500-5000 lbs  
Blind Load Pin: Rocker

Hardy's new lineup of footed load cells with height adjustable rubber feet are used for many standard industrial manufacturing applications, including platform scales, tank weighing, hoppers, and conveyor systems. Rocker and Captive load pin options not only provide a high degree of structural integrity but also make them flexible for a wide variety of installations.

Hardy footed load cell supports are designed to prevent unwanted forces from affecting load cell performance. Height adjustable, self aligning rubber feet make it easy to level the load, whether it is a platform scale or a large tank.

Threaded designs eliminate the potential for lift-off from the foot. Alternatively, a Rocker Pin design provides an additional degree of accuracy by accommodating off-center loading. The rocking action helps prevent unwanted mechanical binding or torsional forces from affecting load cell performance.

Each sensor comes matched by mV/V/ohm and includes true hermetic sealing, C2® Electronic Calibration, and on-board electronic certs. With IP68 (and IP69K for the HI SBHF14 and the HI SBHC14) they provide a high degree of ingress protection. They feature a height adjustable, self aligning rubber foot to combine excellent load introduction with a low profile design. The height is very easy to adjust through rotation of the foot.

### Features

- C2 Electronic Datasheets for EASY Electronic Calibration
- Complete Hermetic Sealing
- Compatible Height Adjustable Rubber Feet
- Matched mmV/V/Ω load cells

### User Benefits at a Glance

- Perfect combination of advanced features and economy for OEMs and System Integrators
- C2® Electronic Calibration
- Industry Standard Load Cell Form factor allows for easy upgrade of existing systems to utilize C2®
- IP68 or IP68/IP69K protection according to EN 60 529

## Advantage® Footed Load Sensor

SPECIFICATIONS	Units	HI SBHF14 & HI SBHC14	HI HBB01
Maximum Capacity (E <sub>max</sub> )	lbs	500 / 1000 / 2500 / 5000	22 / 44 / 110 / 220 / 440 / 550
Max number verification intervals	n <sub>max</sub>	3000	3000
Min load cell verification interval	v <sub>min</sub>	E <sub>max</sub> / 11500	E <sub>max</sub> / 11000
Combined Error	%RO	± 0.0200	± 0.0200
Non-Linearity	%RO	± 0.0166	± 0.0166
Hysteresis	%RO	± 0.0166	± 0.0166
Creep error (30 Minutes) / DR	%RO	± 0.0166	± 0.0166
Temperature effect on min dead load output	%RO/10°C	± 0.0122	± 0.0140
Temperature effect on sensitivity	%RO/10°C	± 0.0100	± 0.0100
Non-Repeatability	%RO		
Rated Output (RO)	mV/V	2 ± 0.1%	2 ± 0.1%
Calibration in mV/V/Ω		Matched	Matched
Zero Balance	%RO	±5	± 5
Excitation Voltage	V	5-15	5-15
Input Resistance	W	1100 ± 50	380 ± 10
Output Resistance	W	1000 ± 2	350 ± 3
Insulation resistance (100VDC)	MW	≥ 5000	≥ 5000
Load Cell Safe Load Limit	%E <sub>max</sub>	200	200
Load Cell Ultimate Load Limit	%E <sub>max</sub>	300	300
Load Cell Safe Side Load	%E <sub>max</sub>	100	100
Compensated Temperature Range	°C	-10 ... +40	-10 ... +40
Operating Temperature Range	°C	-40 ... +80	-40 ... +80
Load Cell Material (metallurgy)		Stainless Steel 17-4PH (1.4548)	Stainless Steel 17-4PH (1.4548)
Sealing		Complete Hermetic Sealing - Glass to Metal Header	Complete Hermetic Sealing - Glass to Metal Header
Protection according to EN 60 529		IP68 (up to 2m water depth) / IP69k	IP68 (up to 2m water depth)
Cable Length	ft	10 (HI SBHF14) 20 (HI SBHC14)	10
Hazardous Certification		HISBHF14 Only: IS Class 1,2,3 Div 1, NI Class 1,2,3 Div 2	IS Class 1,2,3 Div 1, NI Class 1,2,3 Div 2
Legal For Trade		HISBHF14 Only: NTEP COC 04-090	NTEP COC 99-057A1

## HI HBB01 ADVANTAGE® Footed Load Sensor

MODEL NUMBER	CAPACITY LBS [KG]	ØA	ØB	THD TORQUE	CABLE LENGTH FT [M]
HI HBB01-22	22 LB [10KG]	Ø.320 [8.2MM]	Ø.320 [8.2MM]	18 LB-FT [25NM]	10FT [3M]
HI HBB01-44	44 LB [20KG]				
HI HBB01-110	110 LB [50KG]				
HI HBB01-220	220 LB [100KG]				
HI HBB01-440	440 LB [200KG]				
HI HBB01-550	550 LB [250KG]				
HI HBB01-1.1K	1.1 KLB [500KG]	Ø.413 [10.5MM]	Ø.320 [8.2MM]	25 LB-FT [35NM]	

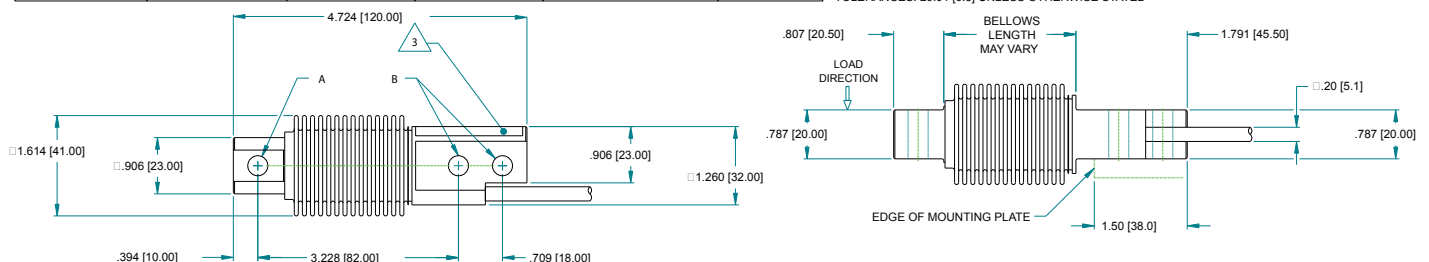

DIMENSIONS- INCHES & [mm]

TOLERANCES: ±0.010 [0.25] UNLESS OTHERWISE STATED

CAPACITY	L1	L2	L3	L4	L5	L6	H1	H2	H3	H4	H5	H6	W1	ØD1	ØD2	BOLT	TORQUE
500LB/1KLB	5.25 [133.4]	0.50 [12.7]	3.00 [76.2]	1.00 [25.4]	2.36 [59.9]	0.59 [15.0]	1.22 [31.0]	1.02 [28.8]	0.59 [15.0]	0.16 [4.0]	0.28 [7.1]	0.58 [14.7]	1.181±0.003 [30.0±.08]	0.709 [18.0]	0.51 [13.0]	.500-20 UNC GRADE 5 [M12 8.8]	66 FT LBS [90Nm]
2.5KLB	5.25 [133.4]	0.50 [12.7]	3.00 [76.2]	1.00 [25.4]	2.36 [59.9]	0.59 [15.0]	1.22 [31.0]	1.20 [30.5]	0.59 [15.0]	0.16 [4.0]	0.28 [7.1]	0.58 [14.7]	1.181±0.003 [30.0±.08]	0.709 [18.0]	0.51 [13.0]	.500-20 UNC GRADE 5 [M12 8.8]	66 FT LBS [90Nm]
5KLB	5.25 [133.4]	0.50 [12.7]	3.00 [76.2]	1.00 [25.4]	2.36 [59.9]	0.59 [15.0]	1.22 [31.0]	1.20 [30.5]	0.59 [15.0]	0.16 [4.0]	0.28 [7.1]	0.58 [14.7]	1.181±0.003 [30.0±.08]	0.709 [18.0]	0.51 [13.0]	.500-20 UNC GRADE 8 [M12 10.9]	88 FT LBS [120Nm]

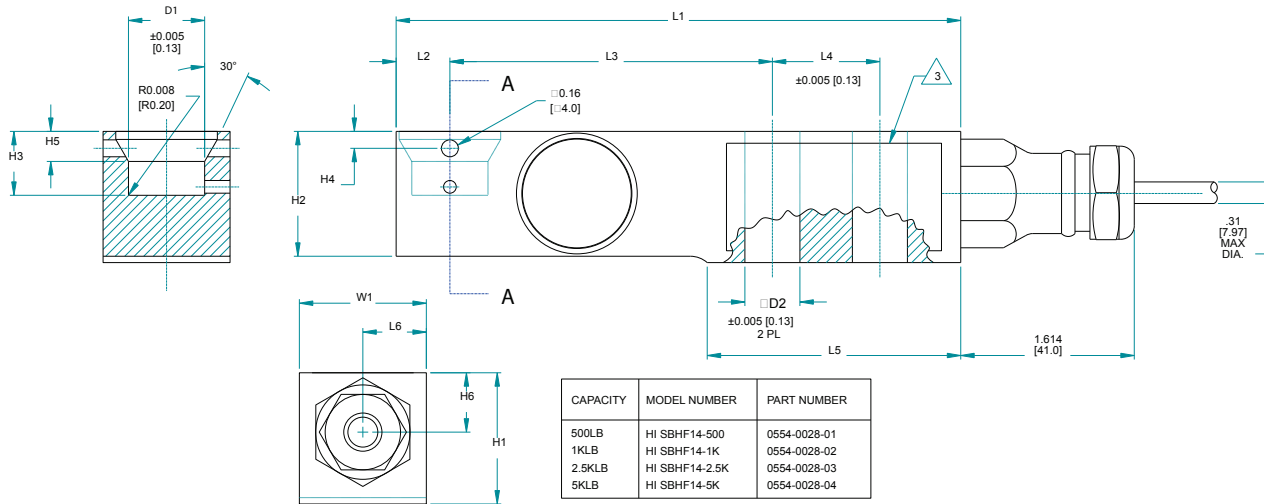

## HI SBHC14 ADVANTAGE® Footed Load Sensor

DIMENSIONS- INCHES & [mm]

TOLERANCES: ±0.015 [0.38] UNLESS OTHERWISE STATED

CAPACITY LBS [kN]	MODEL NUMBER	L1	L2	L3	L4	L5	L6	H1	H2	H3	H4	H5	H6	W1	ØD2	THREAD	MOUNTING BOLT	TORQUE LB-FT [NM]
500 LB [227KG]	HI SBHC14-500	5.25 [133.4]	0.50 [12.7]	3.00 [76.2]	1.00 [25.4]	2.36 [59.9]	0.59 [15.0]	1.22 [31.0]	1.13 [28.8]	0.59 [15.0]	0.16 [4.0]	0.28 [7.1]	0.59 [15.0]	1.181±0.003 [30.0±.08]	0.51 [13.0]	.500-20 UNF-2B	.500-20 UNF GRADE 5 [M12 8.8]	66 [90]
1 KLB [454KG]	HI SBHC14-1K	5.25 [133.4]	0.50 [12.7]	3.00 [76.2]	1.00 [25.4]	2.36 [59.9]	0.59 [15.0]	1.22 [31.0]	1.13 [28.8]	0.59 [15.0]	0.16 [4.0]	0.28 [7.1]	0.59 [15.0]	1.181±0.003 [30.0±.08]	0.51 [13.0]	.500-20 UNF-2B	.500-20 UNF GRADE 5 [M12 8.8]	66 [90]
2.5 KLB [1.13MT]	HI SBHC14-2.5K	5.25 [133.4]	0.50 [12.7]	3.00 [76.2]	1.00 [25.4]	2.36 [59.9]	0.59 [15.0]	1.22 [31.0]	1.20 [30.5]	0.59 [15.0]	0.16 [4.0]	0.28 [7.1]	0.59 [15.0]	1.181±0.003 [30.0±.08]	0.51 [13.0]	.500-20 UNF-2B	.500-20 UNF GRADE 5 [M12 8.8]	66 [90]
5 KLB [2.27MT]	HI SBHC14-5K	5.25 [133.4]	0.50 [12.7]	3.00 [76.2]	1.00 [25.4]	2.36 [59.9]	0.59 [15.0]	1.22 [31.0]	1.20 [30.5]	0.59 [15.0]	0.16 [4.0]	0.28 [7.1]	0.59 [15.0]	1.181±0.003 [30.0±.08]	0.51 [13.0]	.500-20 UNF-2B	.500-20 UNF GRADE 5 [M12 8.8]	89 [120]

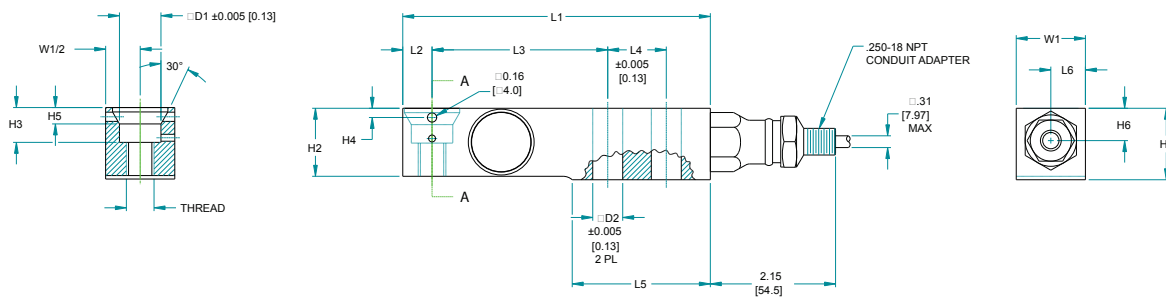

## Advantage® Footed Load Sensor Ordering Information

Advantage® Hermetically Sealed Footed Load Sensor with C2® Calibration					
CAPACITY			MODEL	Shipping Weight	
lbs	kg*	Part #	Hole Type	lbs	kg
500	227	HISBHF14-500	Blind Hole	4	2
1000	454	HISBHF14-1K	Blind Hole	4	2
2500	1134	HISBHF14-2.5K	Blind Hole	4	2
5000	2270	HISBHF14-5K	Blind Hole	4	2

Advantage® Hermetically Sealed Footed Load Sensor with C2® Calibration					
CAPACITY			MODEL	Shipping Weight	
lbs	kg*	Part #	Hole Type	lbs	kg
500	227	HISBHC14-500	1/2-20 Threaded Hole	4	2
1000	454	HISBHC14-1K	1/2-20 Threaded Hole	4	2
2500	1134	HISBHC14-2.5K	1/2-20 Threaded Hole	4	2
5000	2270	HISBHC14-5K	1/2-20 Threaded Hole	4	2

Advantage® Hermetically Sealed Footed Load Sensor with C2® Calibration					
CAPACITY			MODEL	Shipping Weight	
lbs	kg*	Part #	Hole Type	lbs	kg
22	10	HIHBB01-22	Through Hole	1.2	0.5
44	20	HIHBB01-44	Through Hole	1.2	0.5
110	50	HIHBB01-110	Through Hole	1.2	0.5
220	100	HIHBB01-220	Through Hole	1.2	0.5
440	200	HIHBB01-440	Through Hole	1.2	0.5
550	250	HIHBB01-550	Through Hole	1.2	0.5
1100	500	HIHBB01-1.1K	Through Hole	1.2	0.5

C2 WIRE COLOR CODE FLAG LABEL IS FOUND APPROX. 10 IN. FROM END OF SENSOR'S CABLE	
EXCITATION +	RED
EXCITATION -	BLACK
SIGNAL +	GREEN
SIGNAL -	WHITE
C2+	GRAY
C2 -	VIOLET
SHIELD	YELLOW

WARNING: NEVER cut load sensor cable

### Height Adjustable Rubber Foot

Part Number	Description
HIHARF3	Blind Hole Foot for use with HISBHF14 Load Sensors and HIFS Floor Scales
HIHARF6	1/2-20 UNF Threaded Foot for use with HISBHC14 Load Sensors
HIHARF7	Height Adjustable Rubber Foot for HIHBB01 Load Sensors

\*Kg estimated from lbs conversion



HIHARF3 Blind Hole Foot



HIHARF6 Threaded Foot



HIHARF7 Height Adjustable Rubber Foot for HIHBB01 sensors

Hardy Process Solutions  
 10075 Mesa Rim Road  
 San Diego, CA 92121  
 tel. +1-858-278-2900  
 tel. 800-821-5831  
 www.hardysolutions.com  
 hardyinfo@hardysolutions.com



All information within is subject to change without notice. Visit our website for latest specifications. C2, Integrated Technician and ADVANTAGE are registered trademarks of Hardy Process Solutions, Inc.. All other trademarks or registered trademarks are the property of their respective owners.

Footed-Rev B 12/22  
 0401-Foot