

# OneMount™ Advantage® Beam Load Points

## OneMount HI ONELP Load Points with HI HBB01 Beam Sensors

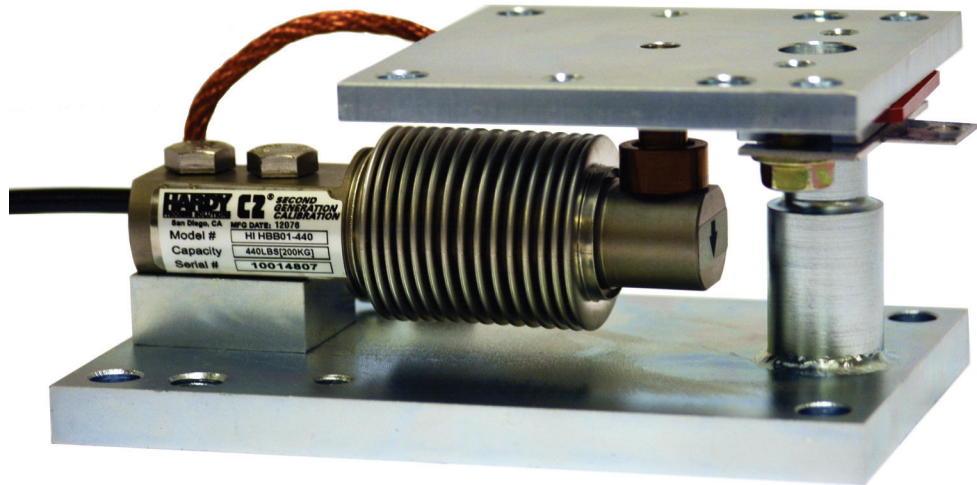

The Hardy OneMount™ with Advantage® beam sensor provides extraordinary flexibility and durability for industrial environments. OneMount load point systems are specifically built to save customers time and money during installation, calibration, and maintenance. Each feature of the load point was intentionally designed based on nearly 100 years of process weighing experience, creating a best-in-class measurement system for check weighers, small hoppers, tank weighing systems, bagging machines and other low capacity industrial applications.

### Accuracy

- Self-centering rocker design maintains alignment under substantial shear forces
- Precision sensor (combined error 0.02% rated output) from 22 lbs – 550 lbs
- Optional Dynamic Stabilization Rods reduce vibration noise on the sensor for better resolution

### Safety

- Best-in-class liftoff and side force ratings for safety under stress
- True glass-to-metal hermetically sealed sensors deliver the ultimate washdown protection (IP68/IP69K)
- C2® cloud-based calibration reduces the risk of accidents or contamination from test weights

### Easy Installation

- Built to carry the full rated capacity without the load cell installed, eliminating the need for expensive dummy load cells and welding fixtures
- Once mount is installed, the load cell slides into place. With minimal tank jacking (1/8"), the two spacers are removed for a live load point
- 360° checking mechanism means load points can be installed in any direction
- C2® weightless calibration for fast startup in high capacity installations with a Hardy weight controller or weight processor

### Easy Maintenance

- Replace load cells with minimal tank jacking (1/8").
- Matched mV/V/ohm load cells are easy to replace without recalibration

### User Benefits

- OEE improvement from consistent, accurate performance, and reduced installation and maintenance time
- Reduced capital investment and labor typically associated with dummy load cells and welding fixtures
- Reduced complexity of system selection and installation from a single, universal design

All information and drawings on these pages are subject to change without notice. Consult website for latest specifications.

# HI HBB01 ADVANTAGE® Load Sensor

SPECIFICATIONS	Units	HI HBB01
Maximum Capacity (E <sub>max</sub> )	lbs	22 / 44 / 110 / 220 / 440 / 550
Max number verification intervals	n <sub>max</sub>	3000
Min load cell verification interval	v <sub>min</sub>	E <sub>max</sub> / 11000
Combined Error	%RO	± 0.0200
Non-Linearity	%RO	± 0.0166
Hysteresis	%RO	± 0.0166
Creep error (30 Minutes) / DR	%RO	± 0.0166
Temperature effect on min dead load output	%RO/10°C	± 0.0140
Temperature effect on sensitivity	%RO/10°C	± 0.0100
Non-Repeatability	%RO	Not Specified
Rated Output (RO)	mV/V	2 ± 0.1%
Calibration in mV/V/Ω		Matched
Zero Balance	%RO	± 5
Excitation Voltage	V	5-15
Input Resistance	Ω	380 ± 10
Output Resistance	Ω	350 ± 3
Insulation resistance (100VDC)	MΩ	≥ 5000
Load Cell Safe Load Limit	%E <sub>max</sub>	200
Load Cell Ultimate Load Limit	%E <sub>max</sub>	300
Load Cell Safe Side Load	%E <sub>max</sub>	100
Maximum Platform Size	N/A	N/A
Compensated Temperature Range	°C	-10 ... ± 40
Operating Temperature Range	°C	-40 ... ± 80
Load Cell Material		Stainless Steel 17-4PH (1.4548)
Sealing		Complete Hermetic Sealing - Glass to Metal Header
Protection according to EN 60 529		IP68 (up to 2m water depth)
Cable Length	ft	10 ft
Hazardous Certification		IS Class 1,2,3 Div 1

## Easy Installation Process

1. Align and level the mounts under the vessel without the load cells installed. The mounts can be installed in any orientation, because of a 360° checking mechanism to ensure accuracy and safety.
2. Lower the vessel onto the mounts and weld or bolt the mounts to the foundation and the vessel.
3. Perform any peripheral pipe welding or add any required attachments.
4. Slide the load cell into place and fasten to the bottom plate.
5. Jack the vessel up 1/8" to remove the shipping/installation brackets (two).
6. Lower the vessel onto the live load point and calibrate using Hardy's C2® cloud-based calibration.

C2 WIRE COLOR CODE FLAG LABEL IS FOUND APPROX. 10 IN. FROM END OF SENSOR'S CABLE	
EXCITATION +	RED
EXCITATION -	BLACK
SIGNAL +	GREEN
SIGNAL -	WHITE
C2 +	GRAY
C2 -	VIOLET
SHIELD	YELLOW

WARNING: NEVER cut a load sensor cable

# HI ONEMT OneMount™

SPECIFICATIONS	Units	HI ONEMT
Capacity	lb	22lb - 550lb
Rated Liftoff Force	lb	225
Rated Overload	lb	1100
Rated Side Force	lb	550
Weight Excluding Load Cell	lb	4
Material	Metallurgy	Electropolished Stainless Steel / Stainless Steel / Plated Steel
Levelling Required		0.4/100 (legal for trade) / 0.8/100 (general applications)

MODEL NUMBER	CAPACITY LBS [KG]	ØA	ØB	THD TORQUE	CABLE LENGTH FT [M]
HI HBB01-22	22 LB [10KG]	Ø320 [8.2MM]	Ø320 [8.2MM]	18 LB-FT [25NM]	10FT [3M]
HI HBB01-44	44 LB [20KG]				
HI HBB01-110	110 LB [50KG]				
HI HBB01-220	220 LB [100KG]				
HI HBB01-440	440 LB [200KG]				
HI HBB01-550	550 LB [250KG]				

TOLERANCES: ±0.01 [0.3] UNLESS OTHERWISE STATED

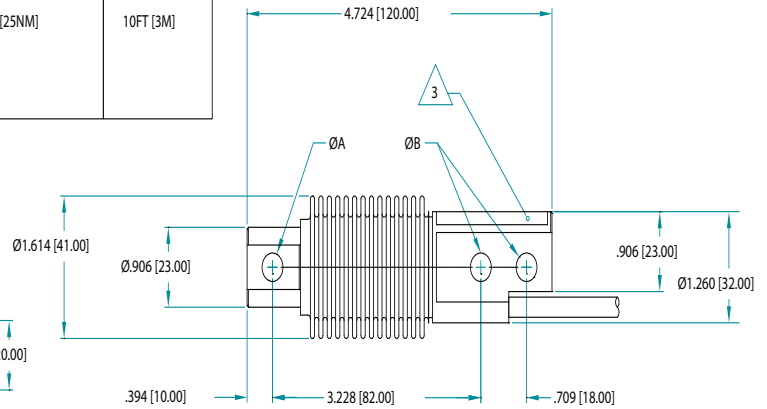
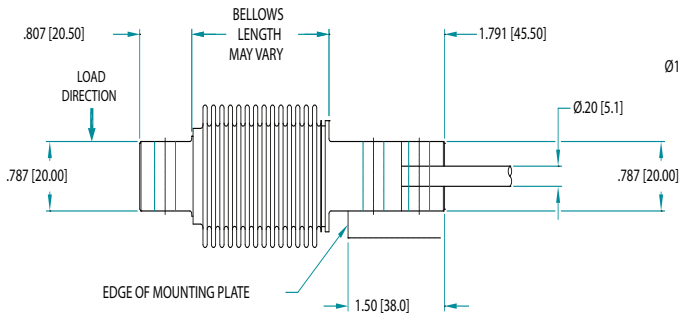

## HI ONEMT Mounts

DIMENSIONS- INCHES & [mm]

CAPACITY LBS [KG]	L1	L2	L3	L4	W1	T1		H1	H2	ØD	MOUNT SCREW	WELD X	WELD Y	MAX LIFT-OFF FORCE	Q1 TORQUE LB-FT [NM]	Q2 TORQUE LB-FT [NM]
22 LB [10KG]	6.50 [165.0]	5.709 [145.00]	3.228 [82.00]	0.39 [10.00]	4.02 [102.0]	0.31 [8.0]	0.49 [12.5]	2.98 [75.6]	3.02 [76.6]	0.394 [10.00]	5/16-18 OR M8 DIN 8.8	0.2 [5.0]	0.2 [5.0]	5.05 T [45KN]	18 LB-FT [25NM]	15 LB-FT [21NM]
44 LB [20KG]																
110 LB [50KG]																
220 LB [100KG]																
440 LB [200KG]																
550 LB [250KG]																

TOLERANCES: ±0.015 [0.38] UNLESS OTHERWISE STATED

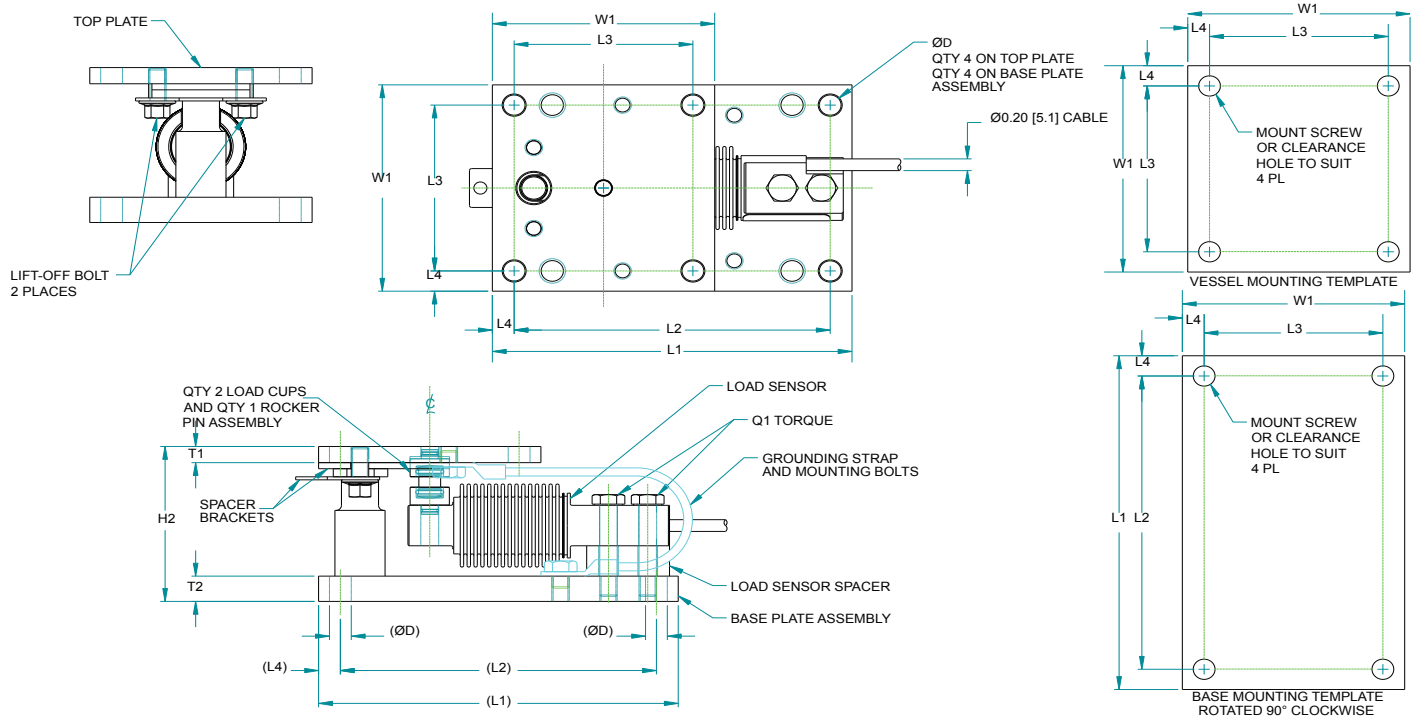

Load Point Assembly (Stainless Steel IP68 Sensor and Stainless Steel Mount)					
Capacity lbs	Capacity kg	Load Point Part #	Load Point Shipping Weight	Sensor Part #	Sensor Shipping Weight
22	9.98	HIONELP-H-22-SS	12 lbs	HIHBB01-22	1.2 lbs
44	19.96	HIONELP-H-44-SS	12 lbs	HIHBB01-44	1.2 lbs
110	49.9	HIONELP-H-110-SS	12 lbs	HIHBB01-110	1.2 lbs
220	99.8	HIONELP-H-220-SS	12 lbs	HIHBB01-220	1.2 lbs
440	199.6	HIONELP-H-440-SS	12 lbs	HIHBB01-440	1.2 lbs
550	249.5	HIONELP-H-550-SS	12 lbs	HIHBB01-550	1.2 lbs

Load Point Assembly (Stainless Steel IP68 Sensor and Alloy Steel Mount)					
Capacity lbs	Capacity kg	Load Point Part #	Load Point Shipping Weight	Sensor Part #	Sensor Shipping Weight
22	9.98	HIONELP-H-22-AS	12 lbs	HIHBB01-22	1.2 lbs
44	19.96	HIONELP-H-44-AS	12 lbs	HIHBB01-44	1.2 lbs
110	49.9	HIONELP-H-110-AS	12 lbs	HIHBB01-110	1.2 lbs
220	99.8	HIONELP-H-220-AS	12 lbs	HIHBB01-220	1.2 lbs
440	199.6	HIONELP-H-440-AS	12 lbs	HIHBB01-440	1.2 lbs
550	249.5	HIONELP-H-550-AS	12 lbs	HIHBB01-550	1.2 lbs

Load Point Assembly (Stainless IP68 Sensor and Electropolished Stainless Steel Mount)					
Capacity lbs	Capacity kg	Load Point Part #	Load Point Shipping Weight	Sensor Part #	Sensor Shipping Weight
22	9.98	HIONELP-H-22-ES	12 lbs	HIHBB01-22	1.2 lbs
44	19.96	HIONELP-H-44-ES	12 lbs	HIHBB01-44	1.2 lbs
110	49.9	HIONELP-H-110-ES	12 lbs	HIHBB01-110	1.2 lbs
220	99.8	HIONELP-H-220-ES	12 lbs	HIHBB01-220	1.2 lbs
440	199.6	HIONELP-H-440-ES	12 lbs	HIHBB01-440	1.2 lbs
550	249.5	HIONELP-H-550-ES	12 lbs	HIHBB01-550	1.2 lbs

OneMount Without Sensors		
Mount Part # Stainless Steel	Mount Part # Alloy Steel	Mount Part # Electropolished Steel
HIONEMT-550-SS	HIONEMT-550-AS	HIONEMT-550-ES

Optional Dynamic Stabilization Rods (550 lb capacity)	
Stainless Steel	Alloy Steel
5504-0074-SS-550LB	5504-0074-AS-550LB



All information within is subject to change without notice. Visit our website for the latest specifications. OneMount is a trademark of Hardy Process Solutions. WAVERSAVER, C2, IT, ADVANTAGE and ANY-WEIGH are registered trademarks of Hardy Process Solutions. Silver Technology Partner is a trademark of Rockwell Automation. All other trademarks or registered trademarks are the property of their respective owners.

**Hardy Process Solutions**  
 10075 Mesa Rim Road  
 San Diego, CA 92121  
 tel. +1-858-278-2900  
 tel. 800-821-5831  
 fax +1-858-278-6700  
 www.hardysolutions.com  
 hardyinfo@hardysolutions.com